

Potable water valve, 2-way, Internal thread

- For potable water applications
- NSF/ANSI 372 - Lead Free
- NSF/ANSI 61 – CLD 23 – Water Quality



5-year warranty



Type overview

Type	DN
B2150PW-R	40

Technical data

Functional data	Valve size [mm]	1.5" [40]
	Potable water certificate	NSF/ANSI 61 NSF/ANSI 372
	Fluid	Potable water
	Fluid temperature	-4...212°F [-20...100°C]
	Body Pressure Rating	600 psi CWP
	Close-off pressure Δps	200 psi
	Differential pressure Δpmax	25psi
	Leakage rate	0%
	Angle of rotation	90°
	Pipe connection	Internal thread NPT (female)
	Installation orientation	upright to horizontal (in relation to the stem)
	Servicing	maintenance-free
	Flow Pattern	2-way
	Cv	144
Materials	Valve body	Lead free brass
	Stem	Lead free brass
	Seat	PTFE
	O-ring	EPDM
	Ball	Chrome plated lead free brass
Suitable actuators	Non Fail-Safe	ARB(X)
	Electrical fail-safe	AFRB(X)

Safety notes



- The ball valve has to be exercised at least once a week, so that the quality of potable water as well as the functionality are not affected.
- The valve has been designed for use in stationary potable water systems and must not be used outside the specified field of application, especially in aircraft or in any other airborne means of transport.
- The valve does not contain any parts that can be replaced or repaired by the user.

Product features

Operating mode The on/off ball valve is adjusted by a rotary actuator. The rotary actuator is connected by an on/off signal. Open the ball valve counterclockwise and close it clockwise.

Installation notes

Notes The ball valve is a regulating device. To fulfil this control task in the long term, the circuit must be kept free from particle debris (e.g. welding beads during installation work).

Permissible installation orientation The ball valve can be installed upright to horizontal. The ball valve may not be installed in a hanging position, i.e. with the stem pointing downwards.

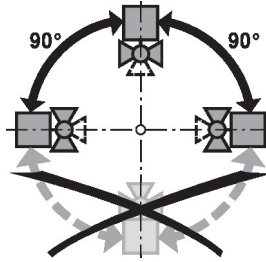

Servicing Ball valves and rotary actuators are maintenance-free. Before any service work on the control element is carried out, it is essential to isolate the rotary actuator from the power supply (by unplugging the electrical cable if necessary). Any pumps in the part of the piping system concerned must also be switched off and the appropriate slide valves closed (allow all components to cool down first if necessary and always reduce the system pressure to ambient pressure level).

The system must not be returned to service until the ball valve and the rotary actuator have been correctly reassembled in accordance with the instructions and the pipeline has been refilled by professionally trained personnel.

Flow direction Please also ensure that the ball is in the correct position (marking on the shaft).

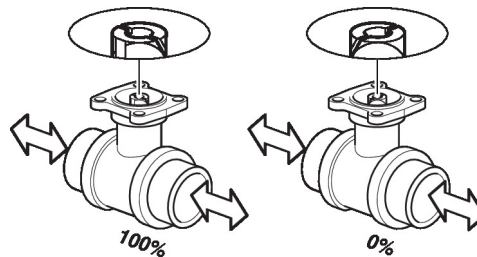

Dimensions

Type	DN	Weight
B2150PW-R	40	3.3 lb [1.5 kg]

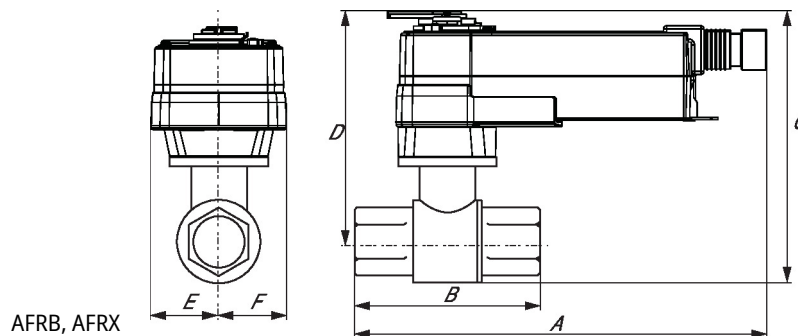

Dimensions

A	B	C	D	E	F
10.5" [267]	4.3" [108]	7.4" [189]	6.0" [153]	2.0" [51]	2.0" [51]

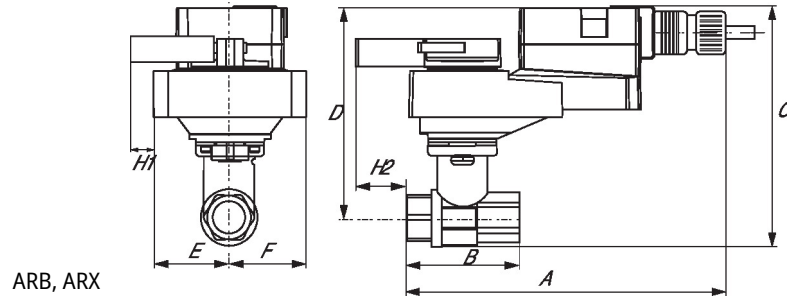

A	B	C	D	E	F
8.8" [224]	4.3" [108]	6.9" [177]	5.6" [142]	1.8" [46]	1.8" [46]

On/Off, Floating point, Non fail-safe, 24 V



5-year warranty

Technical data

Electrical data	Nominal voltage	AC/DC 24 V
	Nominal voltage frequency	50/60 Hz
	Nominal voltage range	AC 19.2...28.8 V / DC 21.6...28.8 V
	Power consumption in operation	2.5 W
	Power consumption in rest position	0.5 W
	Transformer sizing	5.5 VA
	Electrical Connection	Terminal blocks
	Overload Protection	electronic throughout 0...90° rotation
Functional data	Direction of motion motor	selectable with switch 0/1
	Manual override	external push button
	Angle of rotation	90°
	Angle of rotation note	adjustable with mechanical stop
	Running Time (Motor)	90 s / 90°
	Running time motor variable	90 or 150 s
	Noise level, motor	45 dB(A)
	Position indication	Mechanical, pluggable
Safety data	Power source UL	Class 2 Supply
	Degree of protection IEC/EN	IP54
	Degree of protection NEMA/UL	NEMA 2
	Enclosure	UL Enclosure Type 2
	Agency Listing	cULus acc. to UL60730-1A/-2-14, CAN/CSA E60730-1:02, CE acc. to 2014/30/EU
	Quality Standard	ISO 9001
	UL 2043 Compliant	Suitable for use in air plenums per Section 300.22(C) of the NEC and Section 602 of the IMC
	Ambient humidity	Max. 95% RH, non-condensing
	Ambient temperature	-22...122°F [-30...50°C]
	Storage temperature	-40...176°F [-40...80°C]
Servicing	maintenance-free	
Weight	Weight	1.9 lb [0.85 kg]
Materials	Housing material	Galvanized steel and plastic housing

Footnotes †Rated Impulse Voltage 800V, Type action 1.B, Control Pollution Degree 3.

Accessories

Electrical accessories	Description	Type
	Battery backup system, for non-spring return models	NSV24 US
	Battery, 12 V, 1.2 Ah (two required)	NSV-BAT

Electrical installation

✂ INSTALLATION NOTES

- ⚠ Provide overload protection and disconnect as required.
- ⚠ Actuators may be connected in parallel. Power consumption and input impedance must be observed.
- ⚠ Actuators may also be powered by DC 24 V.
- ⚠ Actuators Hot wire must be connected to the control board common. Only connect common to neg. (-) leg of control circuits. Terminal models (-T) have no-feedback.
- ⚠ Actuators are provided with a numbered screw terminal strip instead of a cable.
- ◆ Meets cULus requirements without the need of an electrical ground connection.
- ⚠ **Warning! Live electrical components!**
During installation, testing, servicing and troubleshooting of this product, it may be necessary to work with live electrical components. Have a qualified licensed electrician or other individual who has been properly trained in handling live electrical components perform these tasks. Failure to follow all electrical safety precautions when exposed to live electrical components could result in death or serious injury.

Wiring diagrams

On/Off

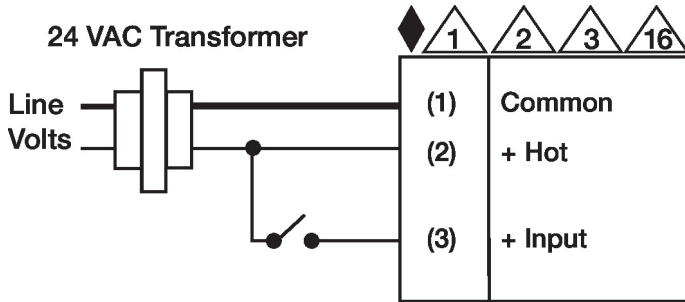

Floating Point

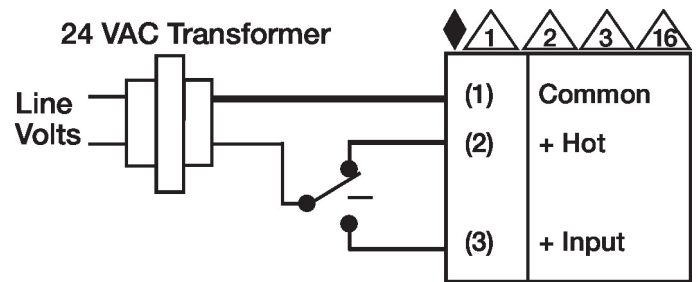

Floating Point - Triac Source

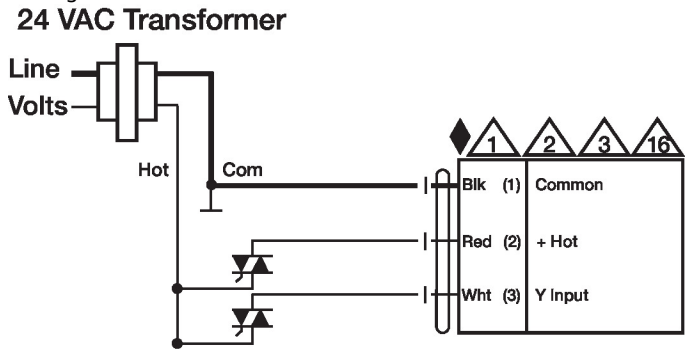

Floating Point - Triac Sink

